

## Vacmagic® VM100

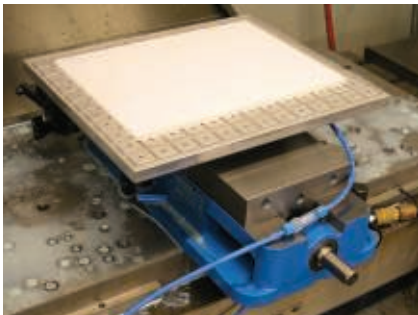

VM100 Base Unit (45375) in Vise



VM100 Base Unit (45375) with VM300 Vacuum Pallet (45150)

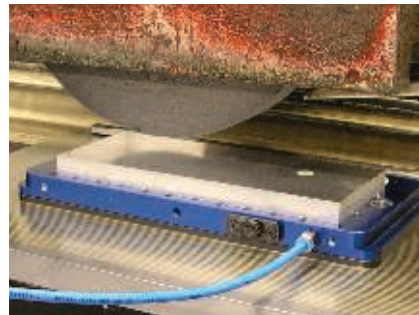

VM100 Base Unit (45375) on a Magnetic Chuck

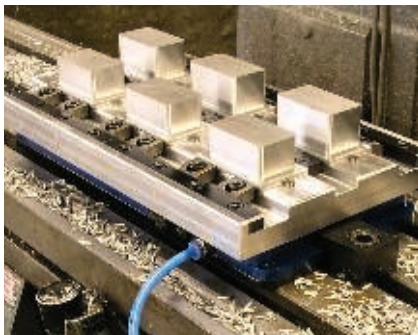

VM100 Base Unit (45375) with a Production Pallet (VM100 Blank Pallet - 45325)

- ▶ Make your own vacuum fixtures - we can help with the design and produce the fixture for your custom application
- ▶ Will accept both blank pallets, the standard 45130 and the larger 45135, as well as the standard vacuum pallet, increasing your vacuum platform to over 14"x12" (360mmx315mm).
- ▶ Remove 12mm pins when grinding/machining thin material, use set screws to locate and aid in holding force

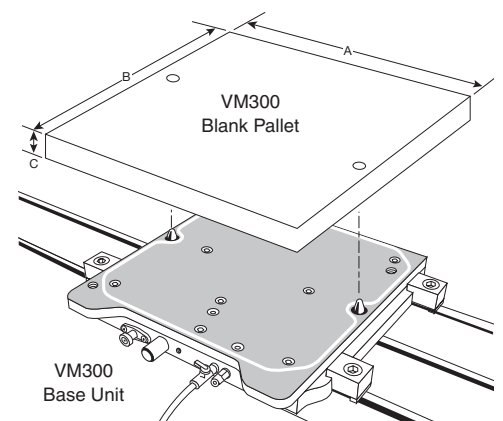
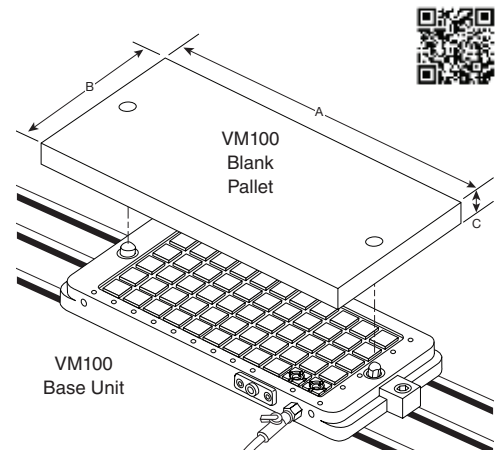

PATENT NO. 7665717

Part Number	Description	A - Length Inch (Metric)	B - Width Inch (Metric)	C - Height Inch (Metric)
<b>VM100</b>				
45325	Blank Pallet	12.5 (318mm)	5.875 (150mm)	1.0 (25mm)
45375	Base Unit with all hardware	12.375 (315mm)	5.5 (140mm)	1.0 (25mm)
45300	VM100 Kit Includes: base unit, 2 blank pallets			
<b>VM300</b>				
45130	Blank Pallet	14.3 (360mm)	12.4 (315mm)	.75 (19mm)
45135	1" thick Blank Pallet	14.93 (379mm)	14.93 (379mm)	1.0 (25mm)
45150	VM300 Vacuum Pallet	14.3 (360mm)	12.4 (315mm)	.625 (16mm)
45160	VM300 Large Vacuum Pallet	33.625 (859mm)	14.5 (368mm)	.625 (16mm)
45175	Base Unit (Receiver) Includes: all hardware	12.75 (323mm)	13.0 (330mm)	1.375 (35mm)
45101	VM300 Kit Includes: base unit, 2 blank pallets, 1 vacuum pallet			

**GASKET MATERIAL** (for VM300 & VM100) See our website, MiteeBite.com, for installation tips

	Part No.	Description	(Inch) Diameter†
<b>Black</b> - Excellent for long cycles and aggressive coolants.	BLACK 45111	by the foot	.170*
	45115	by the foot	.070
	451181	by the foot	.125
	45119	by the foot	.188
<b>White</b> - Excellent for small parts, water based coolants or running dry.	WHITE 45114	by the foot	.170*
	45116	by the foot	.070
	45117	by the foot	.125

\*Replacement size for base units and vacuum pallets. Other sizes listed for custom made pallets.

†Tolerance on all gasket diameter is +/- 10%.



## Vacmagic® VM300



### The All-in-One Pallet Changer and Vacuum Chuck System

In a relatively short amount of time the VM300 has established itself as the vacuum system to which all others are measured. Capabilities include traditional vacuum applications using our standard grid plate and custom vacuum applications (ie: machining blank pallet to suit specific part geometry) and the ability to perform as a rock solid pallet changer. Contact us to schedule an in-house demonstration with one of our highly qualified Manufacturing Representatives.

*One Small Investment = Huge Payoffs!*

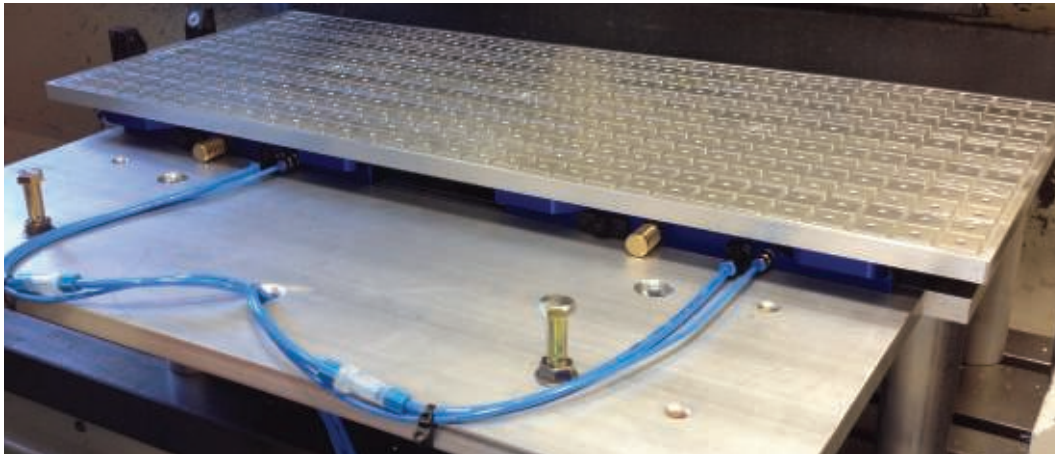

*Best Workholding Product at MACH Exhibition 2006*

*See page 49 for Replacement Parts*

Two VM300 Base Units (45175) and large Vacuum Pallet (45160), bolts supporting oversized workpiece.

- ▶ Simple design keeps cost low
- ▶ Productivity maximized - load pallets while machining
- ▶ Quick-change - swap pallets in 30 seconds or less with precise repeatability
- ▶ Easy to install and set-up
- ▶ Vacuum pallets with M6 threaded holes and textured finish to increase friction
- ▶ Reliable and easy to use - virtually maintenance free
- ▶ Flexible pallet design - limited only by your imagination!
- ▶ No pumps - uses standard shop air
- ▶ Purchase includes a pack of our original Fixture Clamps and Sliding Stops
- ▶ If additional vacuum chambers are needed, drill tap through with M8 thread and plug when not required.

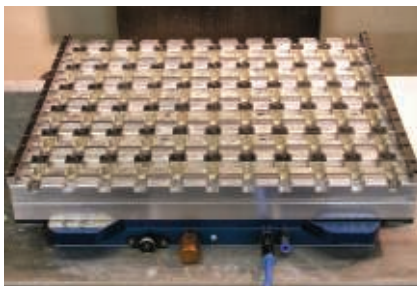

VM300 Base Unit (45175) with a Production Pallet (VM300 Blank Pallet - 45130)

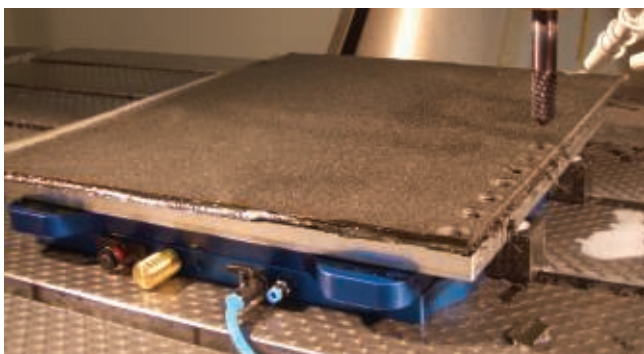

Custom application with graphite.



Never indicate your vise again!

PATENT 7,665,717



## Multi-Power Vac

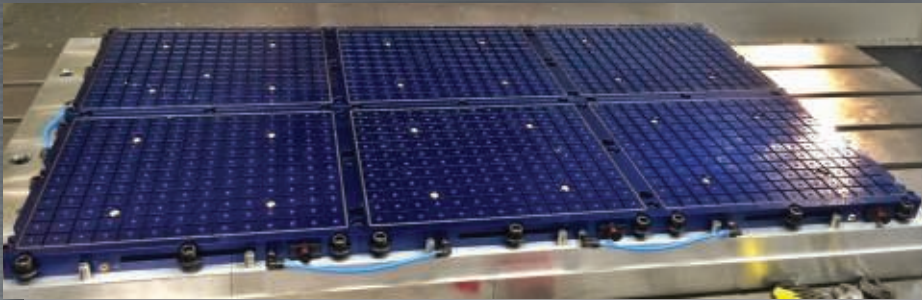

Designed to be easily linked together creating larger platforms

Mitee-Bite is proud to introduce possibly the most universal multi-functional vacuum system in today's market. This system has several unique features to meet your vacuum workholding needs.

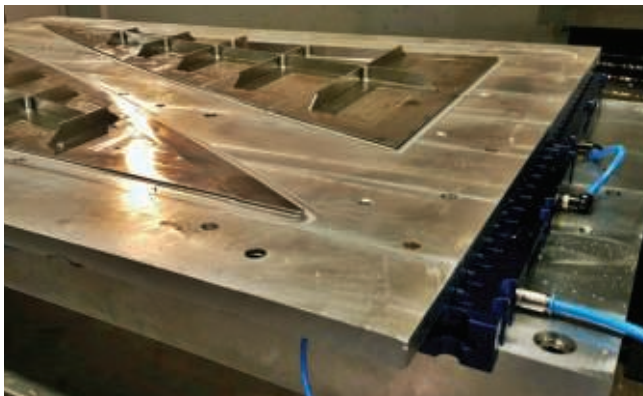

Multiple MPV's shown with large vacuum pallet.

- ▶ Can be powered with our Vacuum Generator (Shop Air) or Vacuum Pumps (page 45)
- ▶ 14"x 16" with textured surface creating additional holding force through friction
- ▶ 4 Vacuum ports allowing user to hold 1-4 small parts or 1 large part (ports can be plugged)
- ▶ Grid plate tapped with M6 threads allowing multiple workholding solutions
- ▶ 6 oversized steel washers machined below the bottom surface allows unit to be used for grinding operations on a magnetic chuck
- ▶ Multiple Vacuum Generators can be used on each pallet if additional CFM is desired
- ▶ Multiple pallets can operate from (1) vacuum generator
- ▶ Coolant Trap may be necessary when using external vacuum source (Trap sold separately)

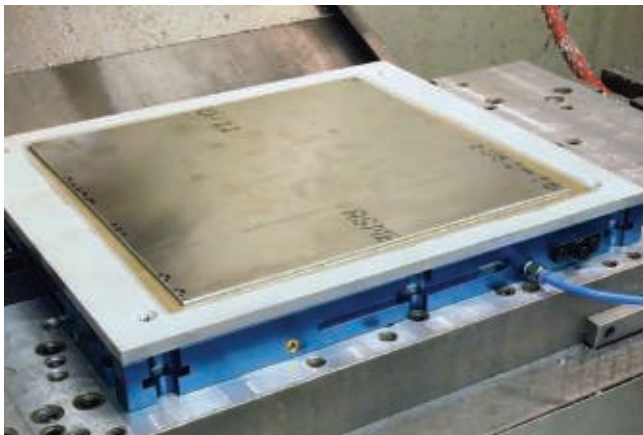

Application using Mitee-Grip™ with sacrificial top plate

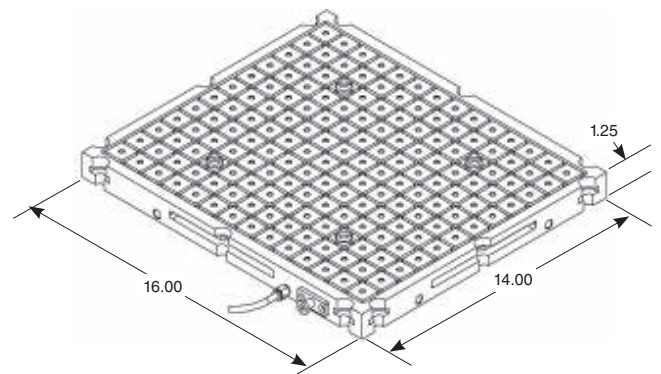
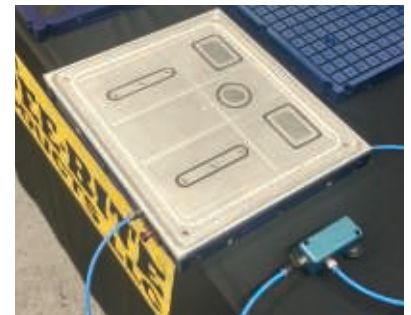

Part No.	Description
46000	1 Multi-Power Vac pallet with Vac Generator including all accessories
46100	Vac Generator with regulator/tubing/brass filter and push to connect fitting
46200	1 Multi-Power Vac pallet without Vac Generator including mounting hardware and tubing
46250	Sacrificial Top Plate with mounting screws
46050	Coolant Trap with hose and fittings